

Per articoli 949*-9449*
 For articles 949*-9449*
 Pour les articles 949*-9449*
 Für Artikel 949*-9449*
 Para los artículos 949*-9449*

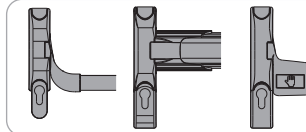

Per articoli 94C*-94F*-94G*
 For articles 94C*-94F*-94G*
 Pour les articles 94C*-94F*-94G*
 Für Artikel 94C*-94F*-94G*
 Para los artículos 94C*-94F*-94G*

Iseo Serrature s.p.a.
 Via San Girolamo, 13
 25055 Pisogne (BS)
 Italy
 Tel +39 0364 8821
 Fax +39 0364 882263
 iseo@iseo.com
 www.iseo.com



Documento non contrattuale. Soggetto a modifica. Guida installazione Trim-Tronic - © 2023 Iseo Serrature S.p.a. (22/11/2023)
 Non contractual document. Subject to change. Trim-Tronic Installation Guide - © 2023 Iseo Serrature S.p.a. (22/11/2023)



Avvertenze - Warnings Avertissements - Warnungen Advertencias



- Leggere il manuale utente prima dell'utilizzo del prodotto al fine di garantire un uso sicuro e corretto.
- Conserva questo manuale come riferimento futuro.
- L'installazione e la manutenzione del prodotto devono essere effettuate da personale tecnico qualificato, adeguatamente addestrato da ISEO.
- Le istruzioni devono essere seguite attentamente durante l'installazione. L'installatore deve fornire all'utente queste istruzioni ed eventuali istruzioni per la manutenzione.
- Nessuna modifica di alcun tipo è consentita, ad eccezione di quelle descritte in queste istruzioni.
- Il prodotto dovrà essere destinato solo all'uso per il quale è stato espressamente concepito e cioè come serratura di porta per ambiente civile e industriale. Ogni altro uso è da considerarsi improprio e pericoloso.
- I collegamenti elettrici devono essere fatti secondo le istruzioni del costruttore e nel rispetto delle normative vigenti.
- Per le riparazioni, rivolgersi esclusivamente a un centro di assistenza tecnica autorizzato dal costruttore.
- Rimuovere l'alimentazione prima di eseguire qualsiasi intervento tecnico che comporti l'apertura o l'accesso alle parti interne del prodotto.
- Smaltire il prodotto separatamente dai rifiuti domestici, secondo le norme e le disposizioni locali.
- *Read this manual prior to use the device in order to ensure a safe and proper use.*
- *Preserve this manual as future reference.*
- *The installation and maintenance of the device must be carried out by qualified technical staff, adequately trained by ISEO.*
- *The instructions should be carefully followed during installation. These instructions and any maintenance instructions should be passed on by the installer to the user.*
- *No modifications of any kind are permitted, except for those described in these instructions.*
- *The product must be destined only for the use for which it is expressly designed and therefore as a door lock for residential, commercial and light industry locations. Any other use is considered improper and dangerous.*
- *The electrical connection must be made according to the constructor's instructions and respecting the regulations in force.*
- *For all repairs, exclusively contact a technical assistance center authorized by the constructor.*
- *Remove the power supply before carrying out any technical service that involves opening or accessing the internal parts of the product.*
- *Dispose of the product separately from household waste, in accordance with local laws and regulations.*



Abbinamento con le serrature tagliafuoco - Combination with fire locks Combinaison avec des serrures coupe-feu - Kombination mit Brandschlössern Combinación con cerraduras cortafuegos

- Il TRIM TRONIC ha lo scopo di abilitare o disabilitare la maniglia esterna delle serrature serie 214 e DINFIR3.
- Il TRIM TRONIC funziona correttamente solo se la serratura non è stata chiusa dall'interno (catenaccio fuoriuscito o quadro maniglia esterno disabilitato) eccetto DINFIR3 funzione E.
 - Non è possibile chiudere in sicurezza la serratura dall'esterno tramite il TRIM TRONIC.
 - Per utilizzo su porte tagliafuoco prevedere un cilindro monoprofilo oppure adeguata protezione del foro cilindro nella serratura.
- The purpose of the TRIM TRONIC is to enable or disable the external handle of the 214 and DINFIR3 series locks.*
- *The TRIM TRONIC works correctly only if the lock has not been locked from the inside (deadbolt out or external square spindle disabled) except DINFIR3 function E.*
 - *It is not possible to securely close the lock from the outside using the TRIM TRONIC.*
 - *For use on fire doors, a single profile cylinder or adequate protection of the cylinder hole in the lock must be provided.*

- Le TRIM TRONIC a pour but d'activer ou de désactiver la poignée extérieure des serrures des séries 214 et DINFIR3.
- Le TRIM TRONIC ne fonctionne correctement que si la serrure n'a pas été verrouillée de l'intérieur (pêne dormant sorti ou poignée extérieure désactivée), à l'exception de la fonction E du DINFIR3.
 - Il n'est pas possible de fermer la serrure de l'extérieur en toute sécurité en utilisant le TRIM TRONIC.
 - Pour une utilisation sur des portes coupe-feu, il faut prévoir un cylindre à profil unique ou une protection adéquate du trou du cylindre dans la serrure.

- Die TRIM TRONIC dient dazu, den Außengriff der Schlösser der Serien 214 und DINFIR3 zu aktivieren oder zu deaktivieren.
- Die TRIM TRONIC funktioniert nur dann korrekt, wenn das Schloss nicht von innen verriegelt wurde (Riegel ausgeschaltet oder Außengriff deaktiviert), mit Ausnahme der DINFIR3-Funktion E.
 - Ein sicheres Schließen des Schlosses von außen ist mit der TRIM TRONIC nicht möglich.
 - Für den Einsatz an Brandschutztüren muss ein Einprofilzylinder oder ein ausreichender Schutz des Zylinderlochs im Schloss vorgesehen werden.

- La función del TRIM TRONIC es activar o desactivar la manilla exterior de las cerraduras de las series 214 y DINFIR3.
- El TRIM TRONIC funciona correctamente sólo si la cerradura no ha sido cerrada desde el interior (cerrojo fuera o panel de la manilla externa desactivado) excepto DINFIR3 función E.
 - No es posible cerrar de forma segura la cerradura desde el exterior utilizando el TRIM TRONIC.
 - Para el uso en puertas cortafuegos, debe preverse un cilindro de perfil único o una protección adecuada del orificio del cilindro en la cerradura.

1

Scelta della mano - Select the hand Choix de la main - Wahl der Hand Elección de la mano

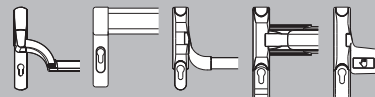
**SX**

MANO SINISTRA
LEFT HAND
MAIN GAUCHE
LINKE HAND
MANO IZQUIERDA

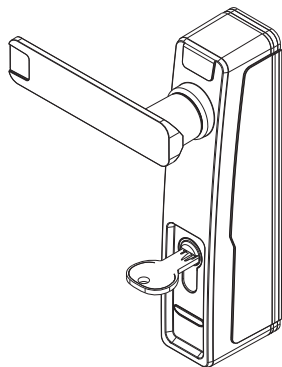
**DX**

MANO DESTRA
RIGHT HAND
MAIN DROITE
RECHTE HAND
MANO DERECHA

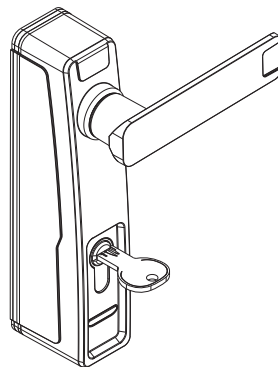

Normativa
Le serrature vengono definite destre DX o sinistre SX, secondo le indicazioni della normativa DIN 107: «Una porta si definisce *destra DX* o *sinistra SX* quando, nel verso di apertura, le cerniere si trovano rispettivamente a *destra* o a *sinistra*»

Standard
Locks are defined as right-handed to the right or left-handed to the left in accordance with DIN 107: «A door is defined as right-handed to the right or left-handed to the left when the hinges are to the right or left in the direction of opening».

Standard
Les serrures sont définies comme étant à droite à droite ou à gauche à gauche selon la norme DIN 107 : «Une porte est définie comme étant à droite à droite ou à gauche à gauche si les charnières sont à droite ou à gauche dans le sens de l'ouverture».

Standard
Die Schlösser sind nach DIN 107 als rechtsdrehend rechts oder linksdrehend links definiert: «Eine Tür ist als rechtsdrehend rechts oder linksdrehend links definiert, wenn die Bänder in Öffnungsrichtung rechts oder links sind».

Estándar
Las cerraduras se definen como derechas a la derecha o izquierdas a la izquierda de acuerdo con la norma DIN 107: «Una puerta se define como derecha a la derecha o izquierda a la izquierda si las bisagras están a la derecha o a la izquierda en la dirección de apertura».

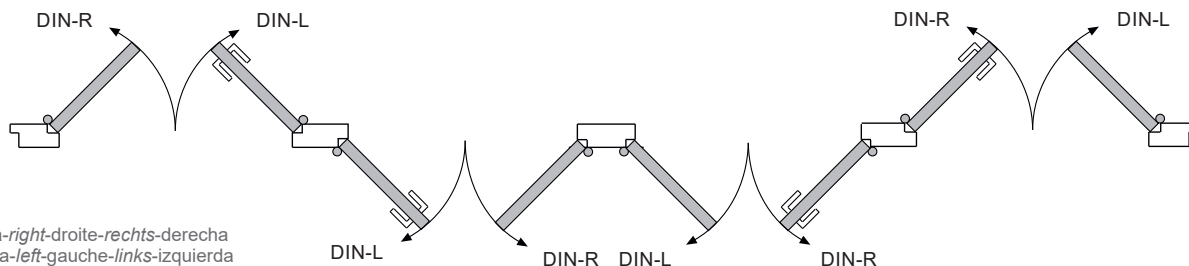

DIN-R :destra-right-droite-rechts-derecha
DIN-L :sinistra-left-gauche-links-izquierda

2

Modalità libero accesso meccanico - Mechanical free access mode Mode de libre accès mécanique - Mechanischer freier Zugriffsmodus Función de acceso mecánico libre

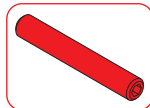
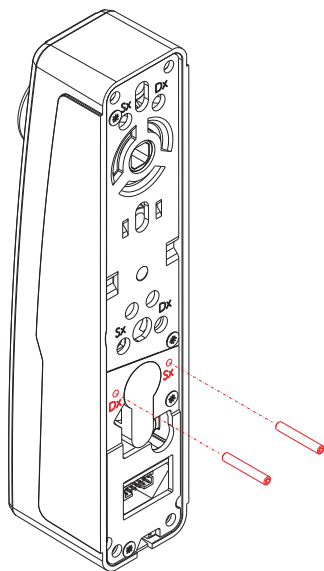
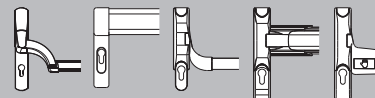
**G1**

- Inserire il grano G1 nel foro SX o DX (porta con apertura sinistra o destra) per disabilitare il dispositivo alla funzione di libero accesso meccanico. L'inserimento di tale grano non permette la rotazione completa della chiave e la possibilità di lasciare il dispositivo abilitato all'apertura.
- If door (left/right opening) is required to be taken of free access mode for period of time, insert screw "G1" from SX. In this way the key won't rotate 360° not allowing the TRIM-TRONIC unit to be left in either disabled or enabled mode.
- Insérer la vis "G1" dans le trou à gauche ou à droite (porte ouverture gauche/droite) pour désactiver le dispositif et permettre la fonction de libre accès mécanique. L'insertion de cette vis ne permet pas la rotation complète de la clé et la possibilité de laisser le dispositif activé pour l'ouverture.
- Den Stift G1 in das Loch LI oder RE einführen um die Vorrichtung für die Funktion des freien mechanischen Zugriffs zu deaktivieren. Das Einführen des Stiftes erlaubt nicht die komplette Drehung des Schlüssels und die Möglichkeit die Vorrichtung bei Öffnung aktiviert zu lassen.
- Introducir el tornillo prisionero G1 del agujero IZ o DER (puerta con abertura izquierda o derecha) para deshabilitar el dispositivo a la función de acceso mecánico libre. La inserción de dicho tornillo prisionero no permitirá así la rotación completa de la llave y la posibilidad de dejar el dispositivo habilitado para la apertura.

2

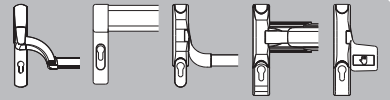

SX

DX

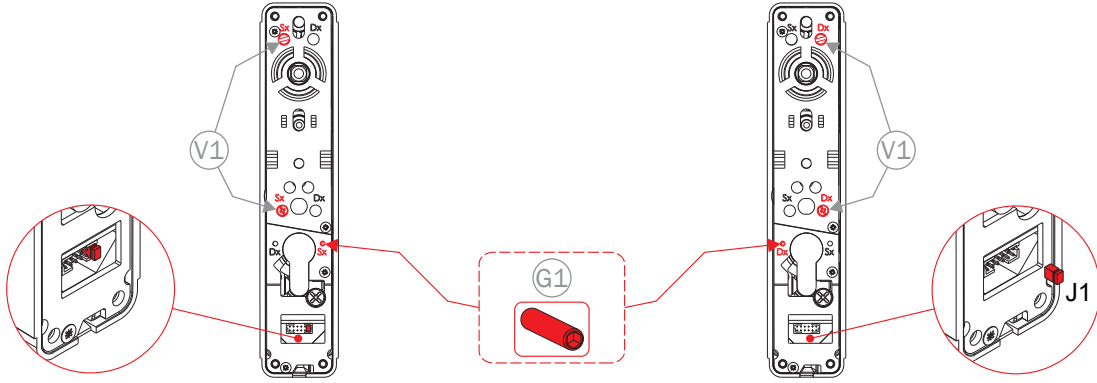

SX

1

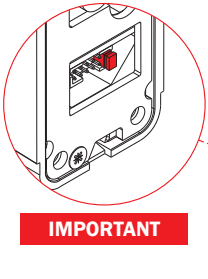

IMPORTANT

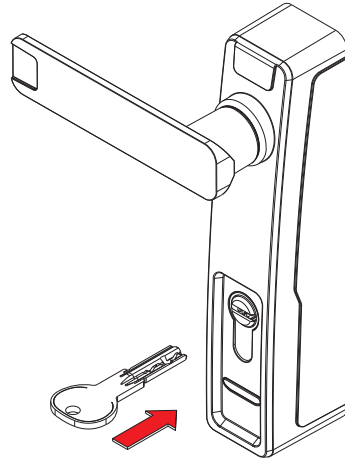
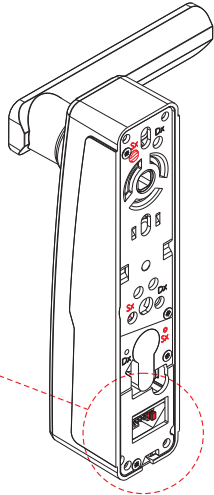

2

3

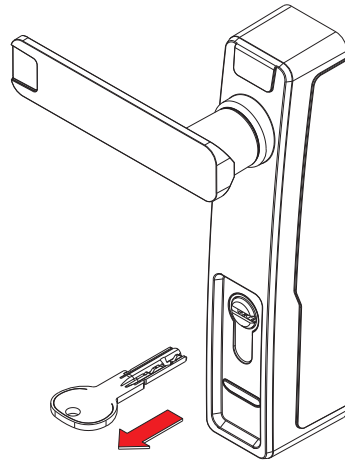
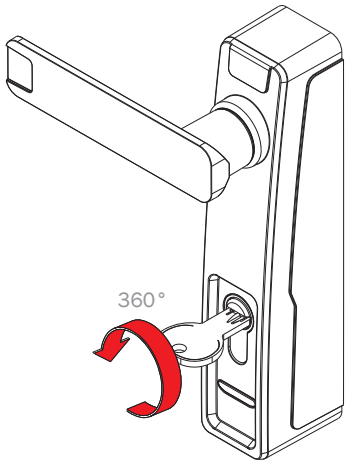

4

5

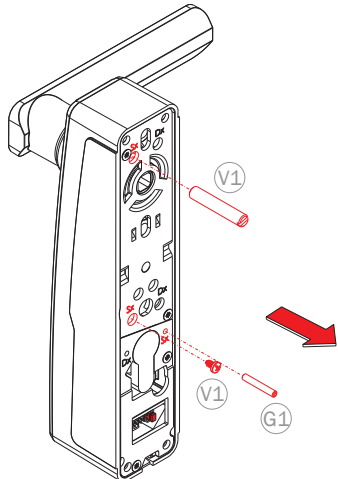

N.B.: per la modalità di libero accesso meccanico non inserire G1 nel foro.
 N.B.: for Mechanical Free Access mode, don't insert G1 in the hole.
 N.B.: pour le mode Libre Accès Mécanique, ne pas insérer G1 dans le trou.
 ANM.: für Mechanischen freien Zugriffsmodus, G1 in das Loch nicht eingeben.
 NOTA: por al función de acceso mecánico libre no insertar G1 en agujero.

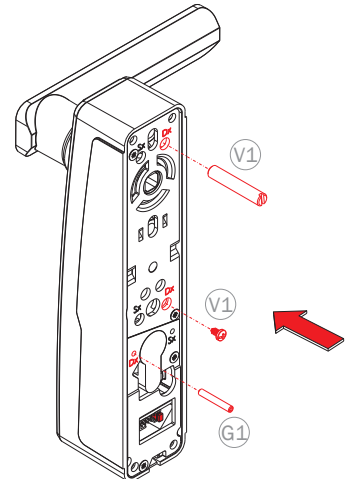

6

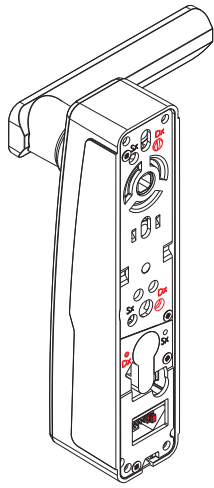

7

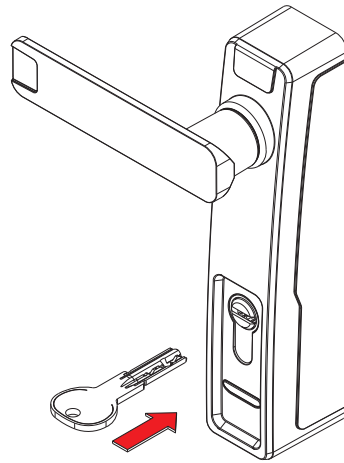

8

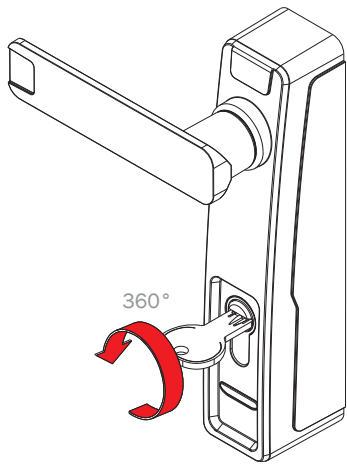

9

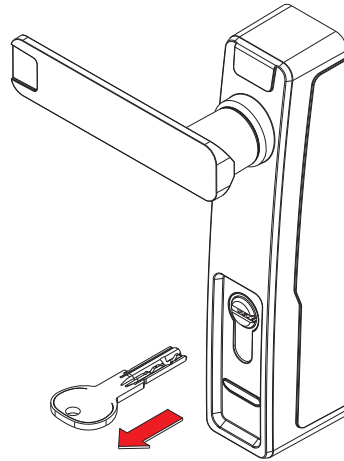

10

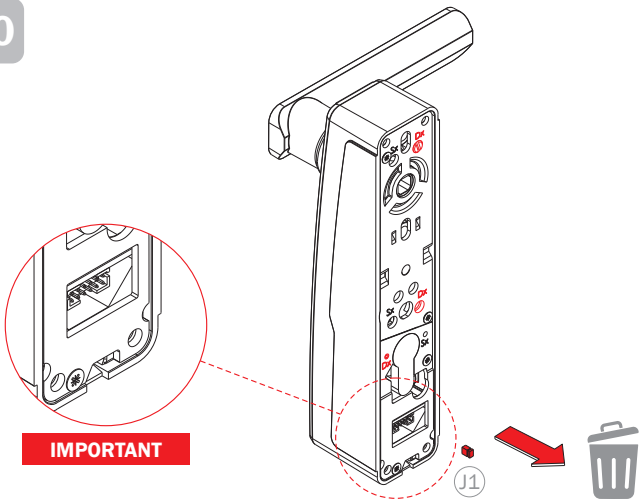

11

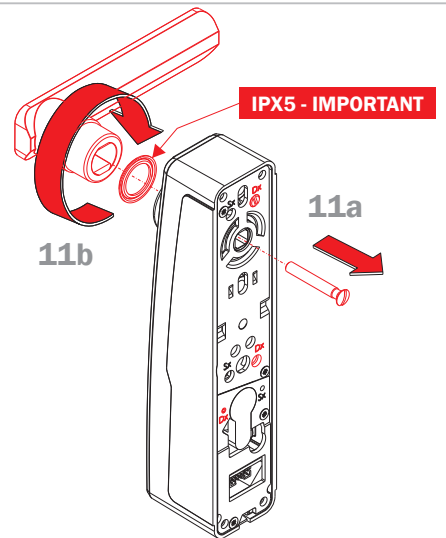

12

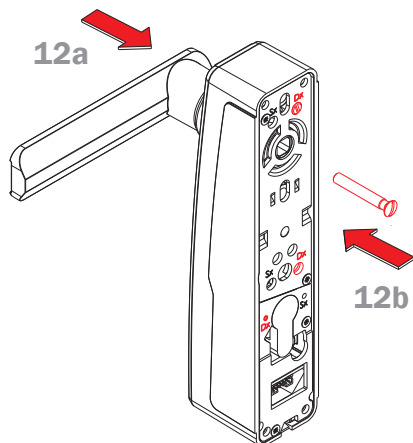

DX

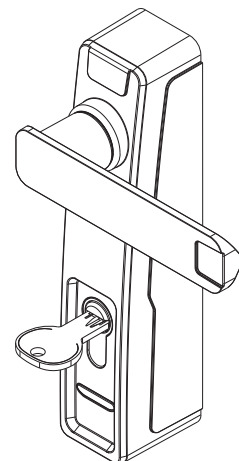

4

Fissaggio della maniglia - Fixing the handle Fixation de la poignée - Befestigung des Griffs Fijación del tirador

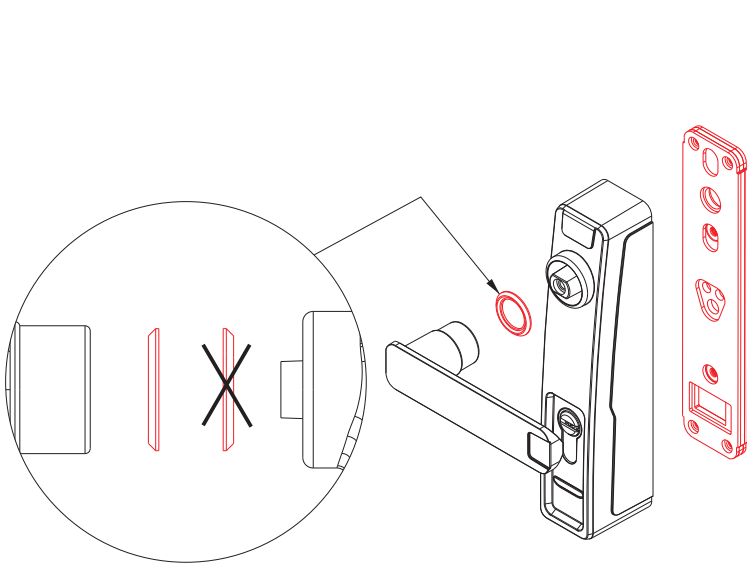
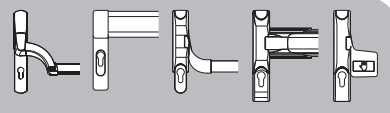

Bloccare con forza la vite
 Tighten the screw thoroughly
 Serrer la vis à fond
 Die Schraube kräftig anziehen
 Apretar a fondo el tornillo



- Il frizionamento sulla vite è normale. Ha funzione antisvitamento
- The screw friction is normal. It has an unscrewing function.
- La friction de la vis est normale. Sa fonction est anti-dévisage.
- Die Reibung der Schraube ist normal. Sie hat eine Abschraubungsfunktion.
- La fricción del tornillo es normal. Con función anti-desatornillamiento.



5

Sostituzione del cilindro - Cylinder replacement Replacement du cylindre - Zylinderersetzung Sostitucion del cilindro

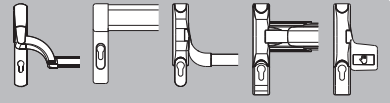

1

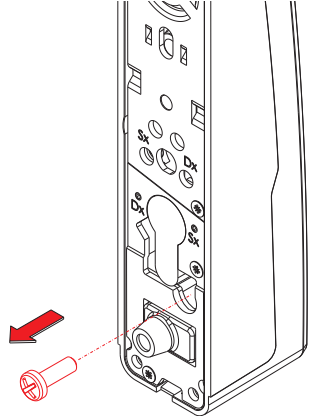

2

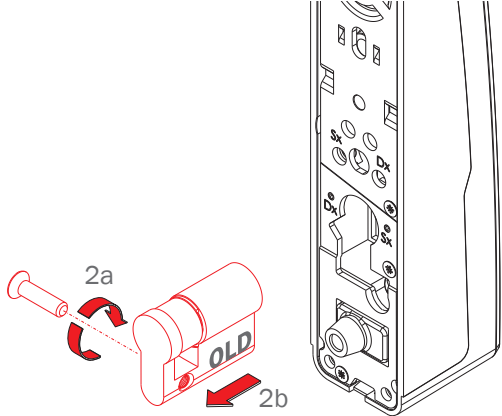

3

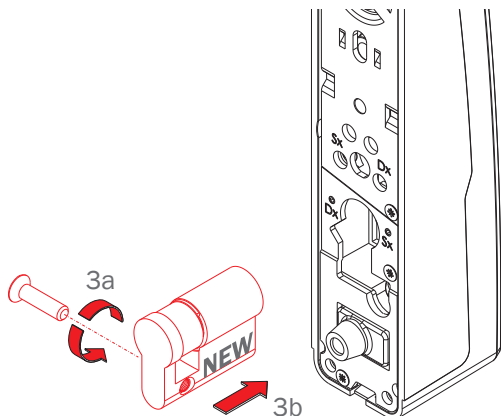

4

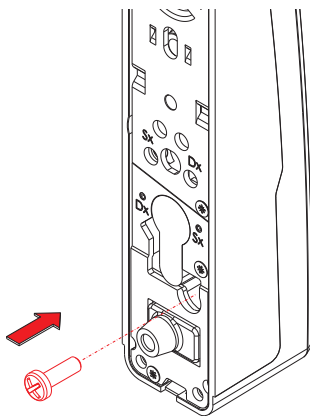

5

6

Foratura della porta - Door drilling
Perçage de la porte - Bohren von Türen
Taladrado de puertas

A titolo esemplificativo è rappresentato il modello 949*
Model 949 is shown as an example*
Le modèle 949* est présenté à titre d'exemple
Das Modell 949 wird als Beispiel gezeigt*
El modelo 949* se muestra como ejemplo

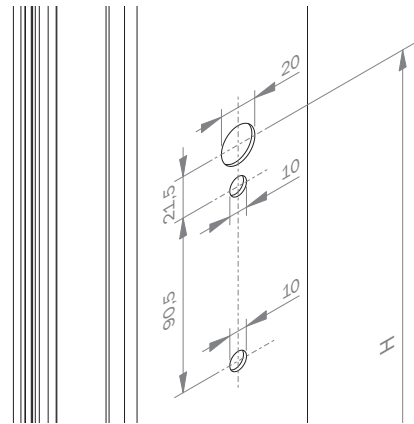
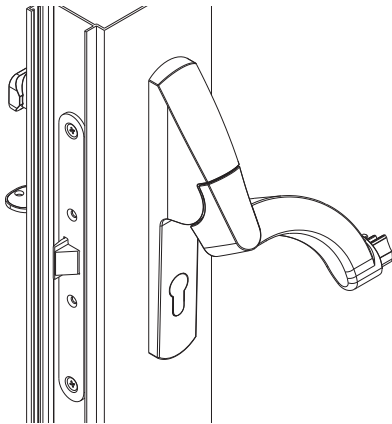
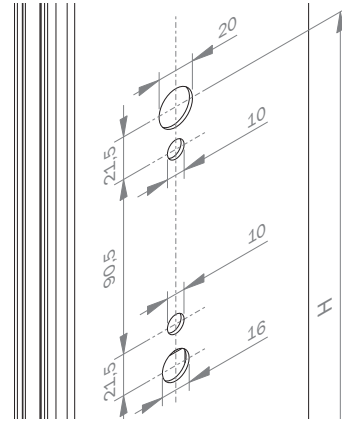
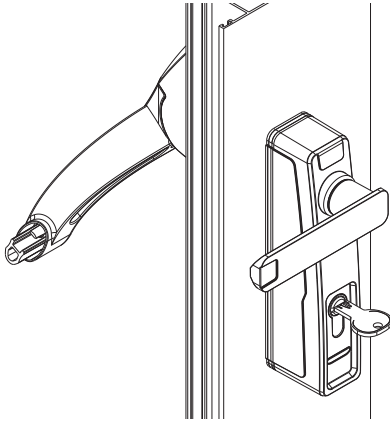
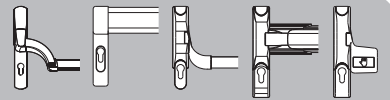

7

Fissaggio del cavo di collegamento e della piastra con mousse
Fixing the connection cable and plate with mousse
Fixation du câble de connexion et de la plaque avec de la mousse
Fixierung des Anschlusskabels und der Platte mit Mousse
Fijación del cable de conexión y de la placa con mousse

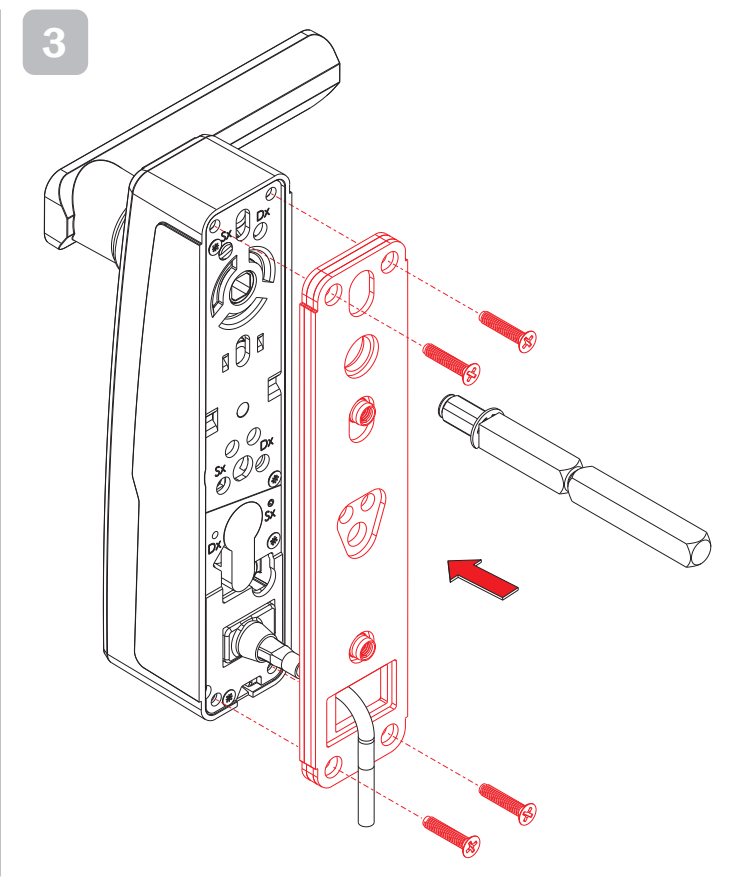
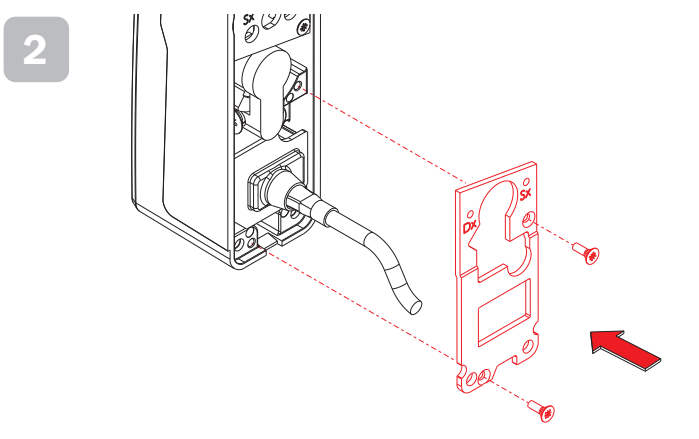
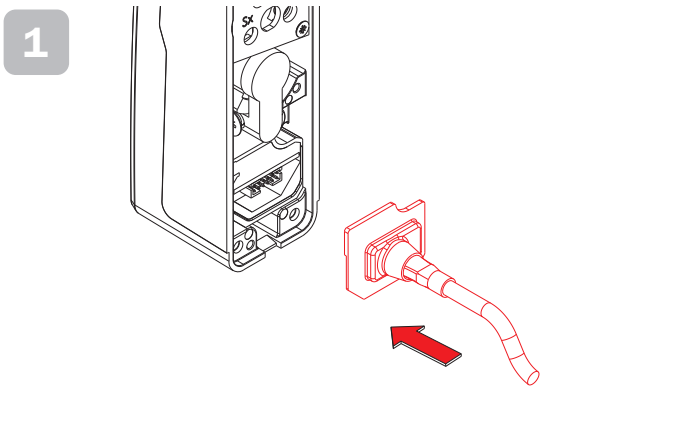
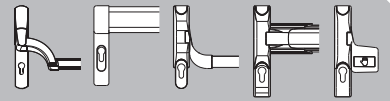

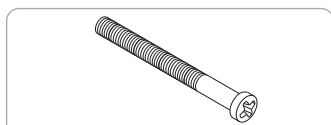
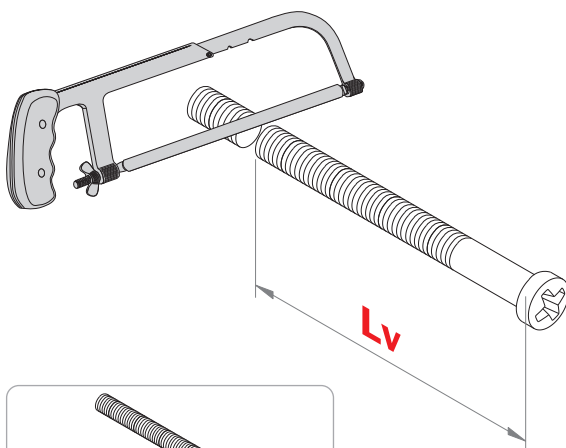
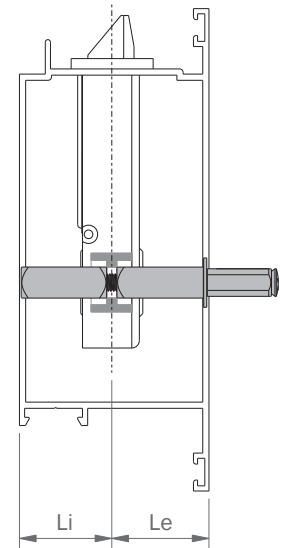
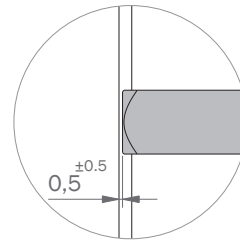
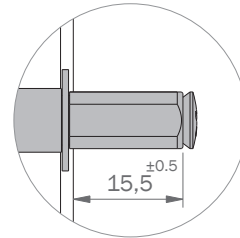
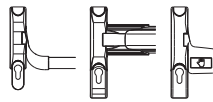
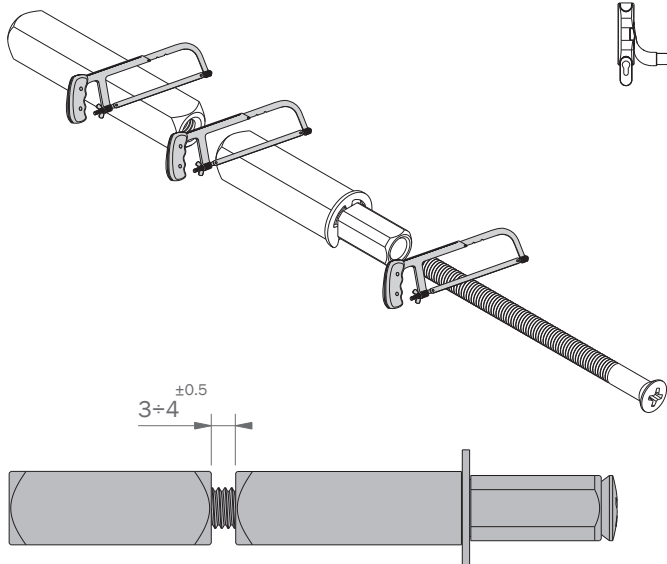
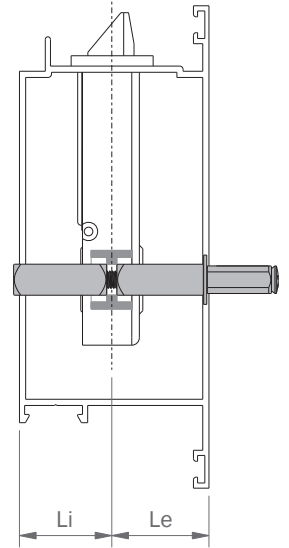
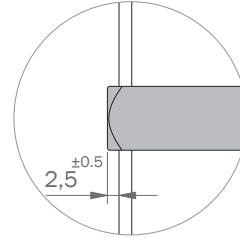
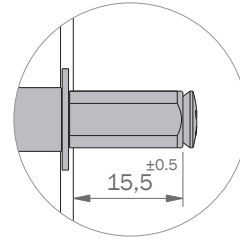
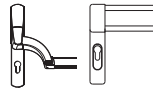
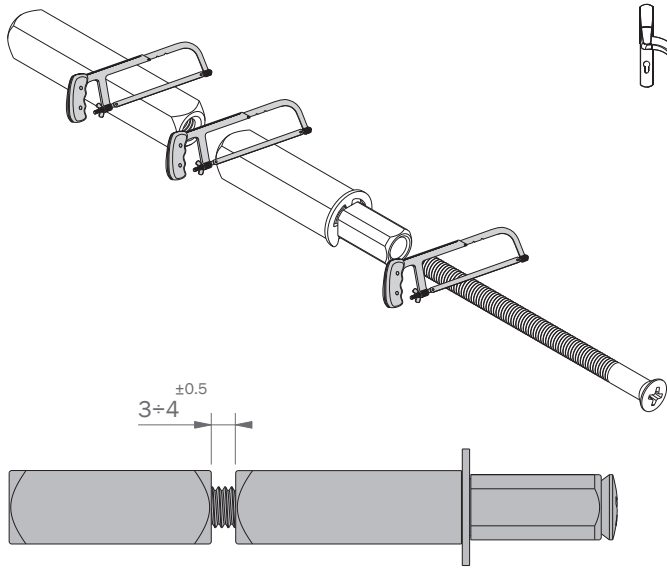
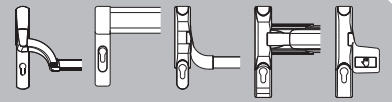

① ② **Lv = E + 8**

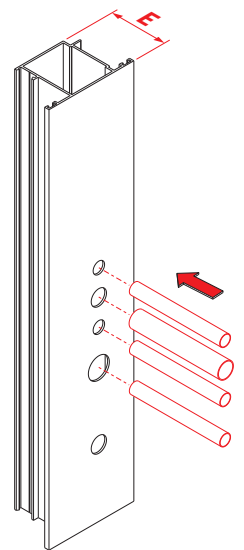
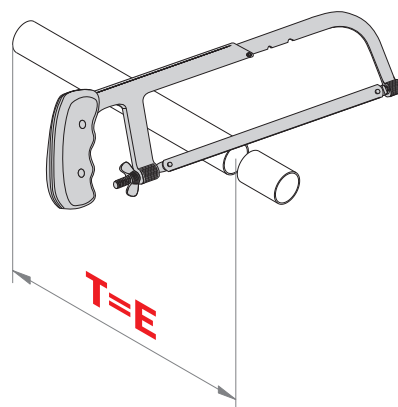

- **Attenzione:** per il corretto funzionamento del dispositivo si raccomanda di rispettare le misure di taglio e relative tolleranze.
- **Attention:** it is highly recommended to comply with the cutting sizes and relative tolerances to ensure the device continues to work properly.
- **Attention:** afin de garantir le fonctionnement correct du dispositif, respecter les mesures de découpage et les tolérances correspondantes.
- **Achtung:** für die korrekte Funktion der Vorrichtung wird empfohlen, das Schnittmaß und die entsprechende Toleranz einzuhalten.
- **Cuidado:** para que el dispositivo funcione correctamente se recomienda respetar la medida de corte y la relativa tolerancia.

9a Fissare il comando sulla porta - Fix the handle onto the door
 Fixer la poignée sur la porte - Die Klinke an die tur befestigen
 Fijar el tirador sobre la puerta

A titolo esemplificativo è rappresentato il modello 949*
 Model 949* is shown as an example
 Le modèle 949* est présenté à titre d'exemple
 Das Modell 949* wird als Beispiel gezeigt
 El modelo 949* se muestra como ejemplo

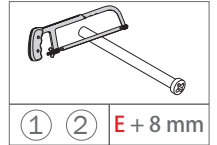
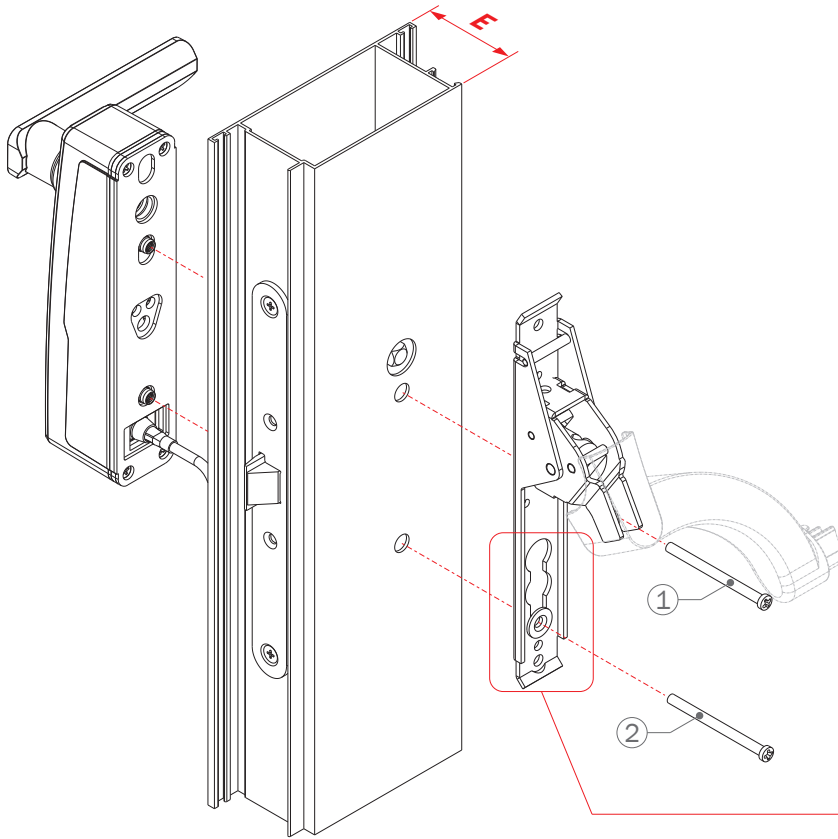
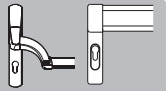

Accessorio in dotazione con i dispositivi antipanico 949* e 9449*
 Accessory supplied with 949* and 9449* panic devices
 Accessoire inclus dans les dispositifs anti-panique 949* et 9449*.
 Zubehör für die Panikvorrichtungen 949* und 9449*
 Accesorio incluido con los dispositivos antipánico 949* y 9449

9b Fissare il comando sulla porta - Fix the handle onto the door
 Fixer la poignée sur la porte - Die Klinke an die tur befestigen
 Fijar el tirador sobre la puerta

A titolo esemplificativo è rappresentato il modello 94C*
 Model 94C* is shown as an example
 Le modèle 94C* est présenté à titre d'exemple
 Das Modell 94C* wird als Beispiel gezeigt
 El modelo 94C* se muestra como ejemplo

